

Product Features

- Wall mounted
- Integrated connection for handshower hose
- Fits handshower hose with conical nut
- ½" NPT female inlet
- Handshower holder adjustable to 6 positions
- Protection against backflow provided by check valve

Code Compliance

This unit meets or exceeds the following:

- ASME A112.18.1
- CSA B125.1
- Listed by IAPMO
- Approved for use in Massachusetts

Available Finishes

Chrome	27508001
Oil Rubbed Bronze	27508621
Steel	27508801
Brushed Nickel	27508821
Polished Nickel	27508831
Polished Brass	27508931

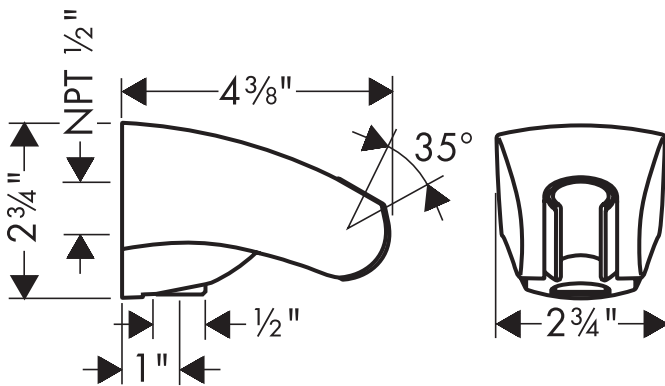

The measurements shown are for reference only.

Products and specifications shown are subject to change without notice.

Specification sheet revised 1/2008