

M2-4701

FLEETWOOD LEVER 4-HOLE KITCHEN MIXER WITH PULL-OUT HAND SPRAY

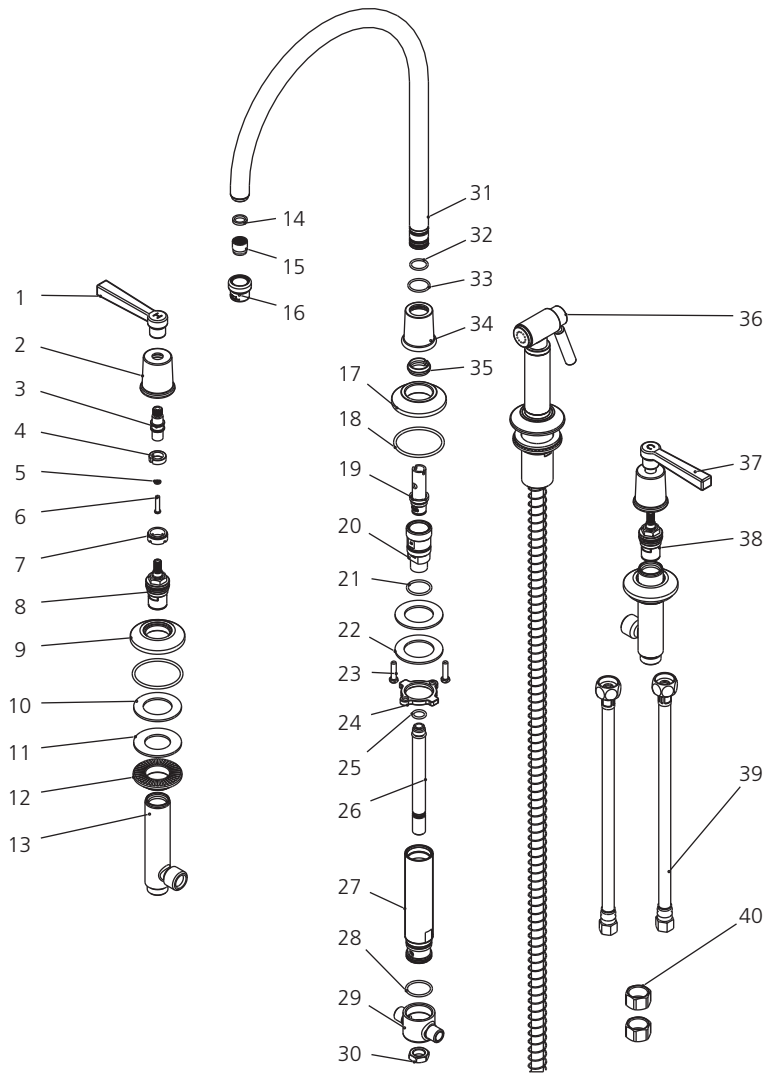

1	Handle (H) (029686H-T)	15	Aerator insert (553661N)	29	Connector (014083W)
2	Canopy (018295)	16	Oil-seal (010519N)	30	Nut (070053)
3	Stem extension (110409)	17	Escutcheon (303467)	31	Spout assembly (139349W)
4	Clip (012242)	18	O-ring (004617)	32	O-ring (004015N)
5	Washer (013570)	19	Diverter (501013N)	33	O-ring (004109N)
6	Screw (008486)	20	Diverter seat (213009W)	34	Canopy (000116)
7	Adaptor (057507)	21	O-ring (004074N)	35	Clip (012003)
8	Cartridge (H) (507175W)	22	Washer (013018)	36	Side spray (533137W)
9	Escutcheon (071473)	23	Screw (008045)	37	Handle (C) (029686C-T)
10	Oil-seal (010017)	24	Nut (009012)	38	Cartridge (C) (507176W)
11	Washer (013158)	25	O-ring (004026N)	39	Flexible hose (105750W)
12	Nut (009834)	26	Connecting tube (035231N)	40	Copper nuts (504003)
13	Body (061893W)	27	Body (066121W)		
14	Aerator housing (305856-54)	28	O-ring (063091N)		

Standards

IAPMO/cUPC Listed
Meets NSF 61-9
Meets A112.18.1

Flow Rate

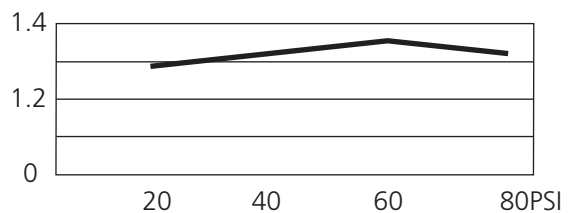

Please note :

Final achievable flow rate is dependent on the outlets fitted, see relevant outlets (spouts, roses, sprays) for fully assembled product flow rate.