

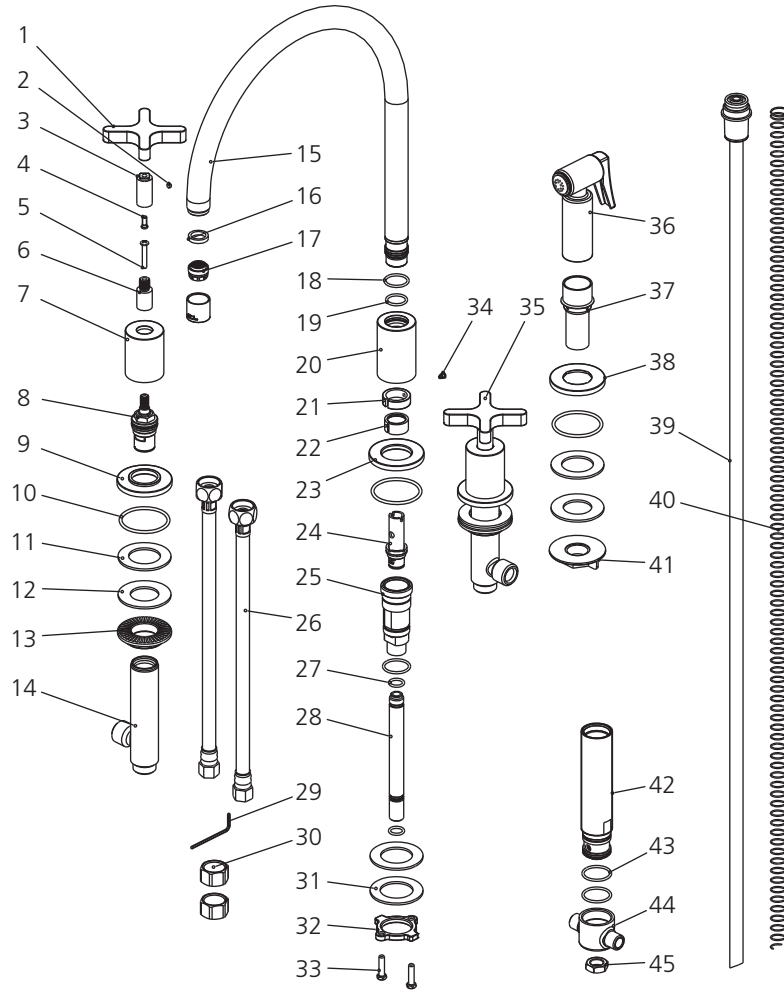

# K1-3600

CROSS HANDLE 4-HOLE KITCHEN MIXER WITH PULL-OUT HAND SPRAY



1	Handle ( H ) (069688H)	16	Oil-seal (010095N)	31	Washer (013018)
2	Set screw (053205)	17	Aerator assembly (553648N)	32	Nut (009012)
3	Stem extension (205417)	18	O-ring (063072N)	33	Screw (008045)
4	Screw (008774)	19	O-ring (004074N)	34	Screw (053197)
5	Screw (065152)	20	Canopy (000888)	35	Handle ( C ) (069688C)
6	Adaptor (205434)	21	Clip (012101)	36	Side spray (503125W)
7	Canopy (018419)	22	Clip (012195N)	37	Holster (017005)
8	Cartridge (507907N)	23	Escutcheon (303427)	38	Escutcheon (220640)
9	Escutcheon (071308)	24	Diverter (501013N)	39	Spray hose (511422W)
10	O-ring (004072N)	25	Diverter seat (213129W)	40	Spring (005195)
11	Oil-seal (010017)	26	Flexible hose (105750N)	41	Nut (009008)
12	Washer (013158)	27	O-ring (004026N)	42	Body (066121W)
13	Nut (009834)	28	Conneting tube (035231N)	43	O-ring (063091N)
14	Body (061893W)	29	Allen key (031003)	44	Connector (014083W)
15	Spout assembly (139836W-54)	30	Alternative nut (504003)	45	Nut (070053)

## Standards

IAPMO/cUPC Listed  
Meets NSF 61-9  
Meets A112.18.1

## Flow Rate

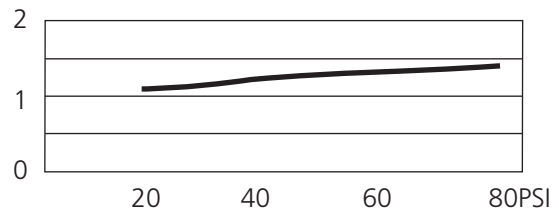

Please note :

Final achievable flow rate is dependent on the outlets fitted, see relevant outlets (spouts, roses, sprays) for fully assembled product flow rate.