

SPECIFICATIONS FOR
FARMHOUSE 3018

NativeStone™ Collection

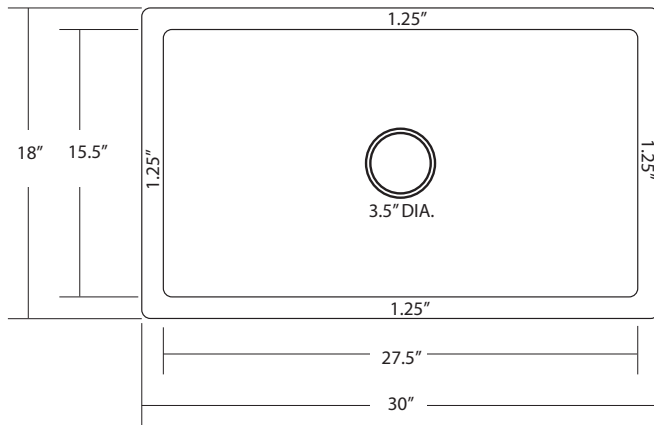

Front View:

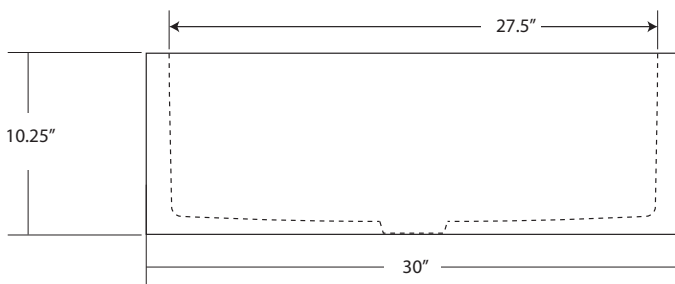

Side View:

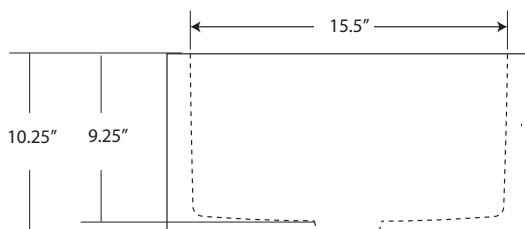

NSK3018-A Ash
NSK3018-S Slate
NSK3018-P Pearl

PRODUCT DETAILS

- * 30" x 18" x 10.25" OD
- * 27.5" x 15.5" x 9.25" ID
- * Dimensions are not exact and may vary $\pm 1/4"$
- * 3.5" drain opening
- * Sealed with impermeable nano sealer

INSTALLATION

- * Undermount

COORDINATING PRODUCTS

- * Drains: DR320 or DR340
- * Bottom Grid: GR971

STANDARDS COMPLIANCE

- * UPC / cUPC

IMPORTANT

Due to the handcrafted nature of this product, it will vary in finish, texture, and other details. Dimensions may vary up to $1/4"$. We recommend waiting for the actual product before making any installation cuts.