

OPUS SERIES

Lavatory Conical Bowl

Model CR-1620 Undermount

CRO-1620 Undermount with overflow

CRT-1620 Topmount

CRT0-1620 Topmount with overflow



CR-1620

FEATURES

- Premium grade T-304 stainless steel
- 6-1/4" depth • 18 gauge
- StoneGuard™ undercoating
- SpecPlus™ edge
- Lustrous satin with highlighted rim
- Fits 21" sink base
- 1-1/2" drain opening
- Supplied with cutout template, fasteners and instructions
- Complies with ASME A112.19.3-2000, UPC®
- Lifetime Limited Warranty



ASME A112.19.3-2000

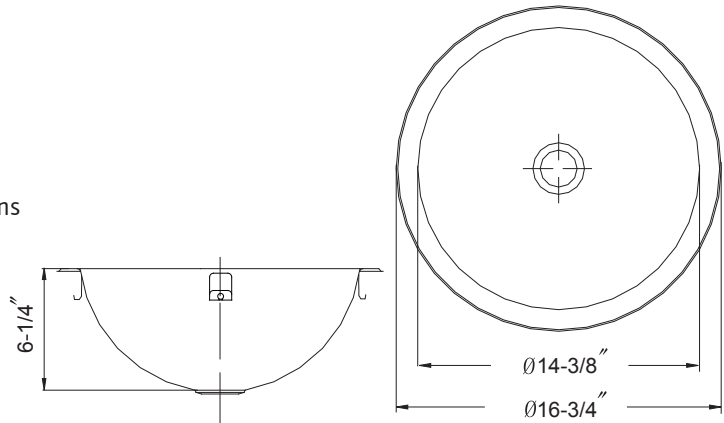

OPTIONAL ACCESSORIES

Grid Drain : FD-10

Overflow Assembly : OD-10

OVERALL DIMENSIONS	EACH BOWL	CUTOUT SIZE	PACKAGING*	WEIGHT*
Ø16-3/4"	Ø14-3/8"	See Template	1/32/40 pcs.	7/260/260 lbs.

*Standard packaging: Single boxed /Pallet of single boxed/Pallet of bulk pack.
All dimensions are in inches. Specifications subject to change without notice.

Installation profile

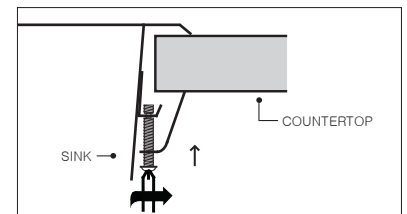
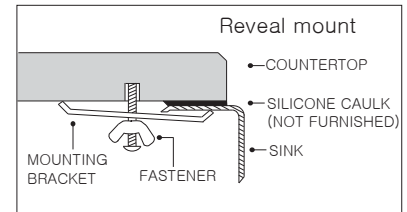
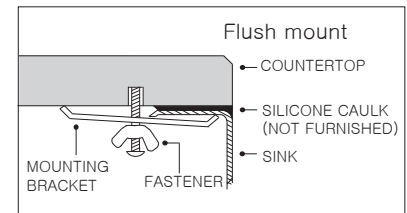

Project/Job name

Architect/Engineer

Contractor

Model

Q'ty

Notes