

Features

- Forged brass valve body construction
- 3/4" NPT connections (2 inlet & 2 outlet)
- High-flow rate: 18.2 gpm (68.9 L/m) @ 60 psi
- Integral service stops
- Built-in check valves to prevent crossflow
- Single-handle temperature mixing
- Thermostatic anti-scald protection
- Genuine Vernet® mixing cartridge featuring
 - Thermoplastic polymer construction to limit limescale build-up
 - Integrated filter screens
 - Paraffin wax element

NOTE: Requires separate shut-off/volume control valve(s)

Codes/Standards Applicable

Specified model meets or exceeds the following:

- ASME A112.18.1-2005/CSA B125.1-05
- ASSE 1016
- ADA (with lever handles)
- Listed IAPMO/cUPC®

00-388N-000

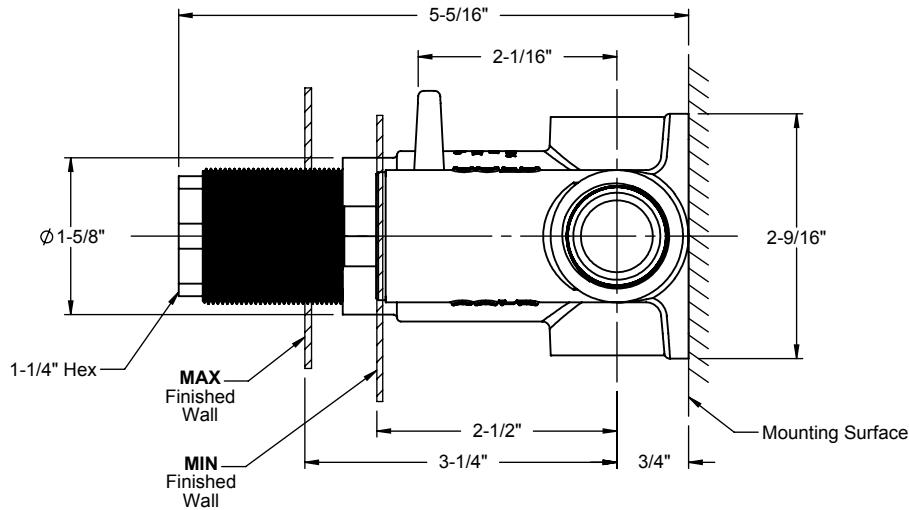
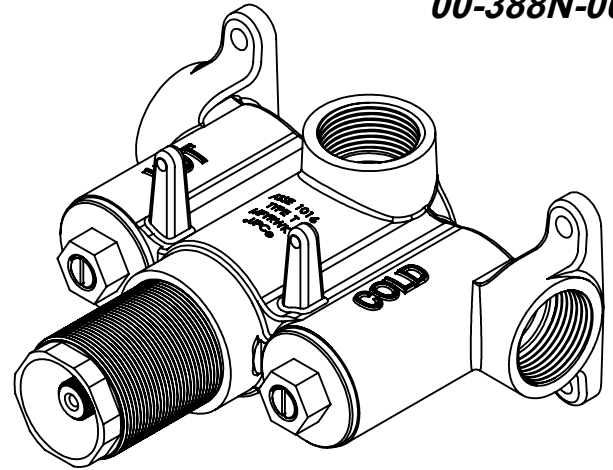

SIDE VIEW
FRONT VIEW

ALL DIMENSIONS SHOWN TO NEAREST 1/16"

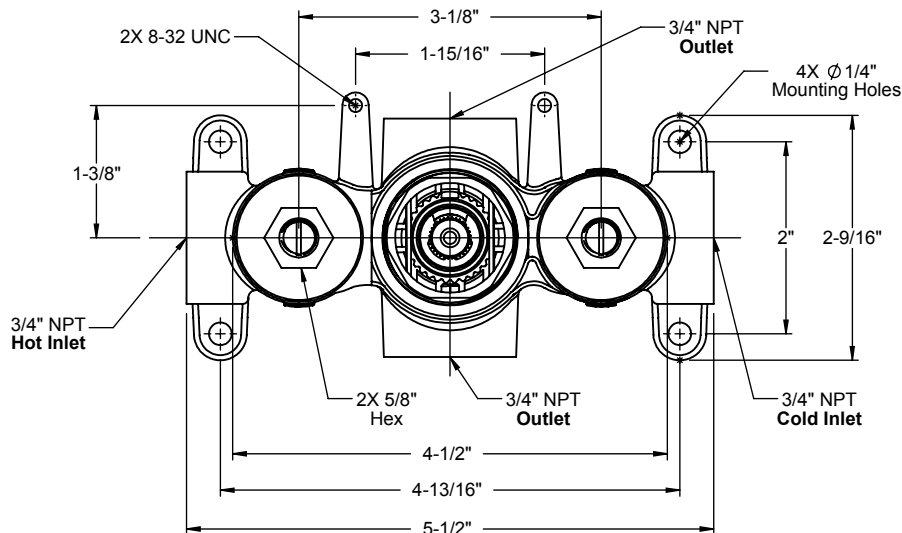

Features

- Over 30 finishes
 - All brass construction
 - Traditional or transitional faceplate
 - Engraved brass temperature ring
 - 100° F safety stop button with manual override
 - Handles to match all Harrington Brass series
- See www.harringtonbrassworks.com for complete selection

XX-388N1T-XX

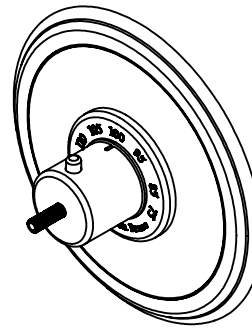

XX-388N2T-XX

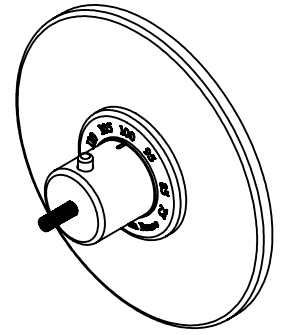

Codes/Standards Applicable

Specified model meets or exceeds the following:

- ASME A112.18.1-2005/CSA B125.1-05
- ASSE 1016
- ADA (with lever handles)
- Listed IAPMO/cUPC®

XX = Series & Handle

Traditional Faceplate

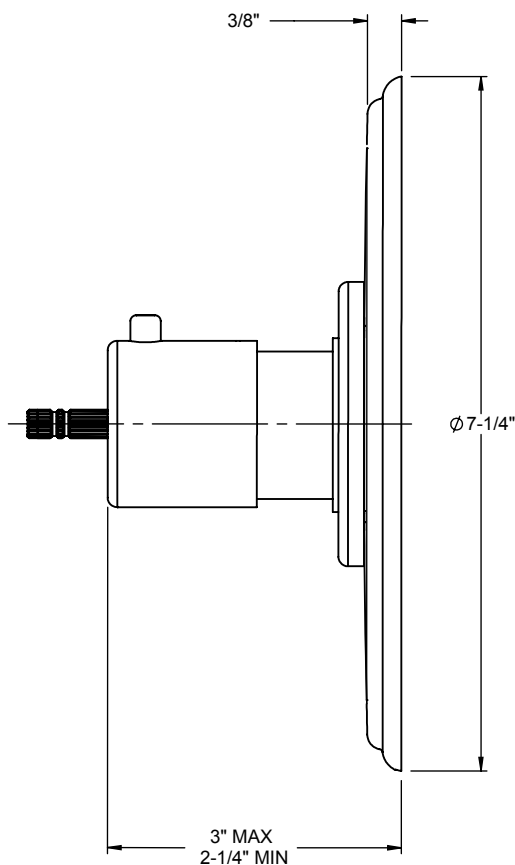

Transitional Faceplate

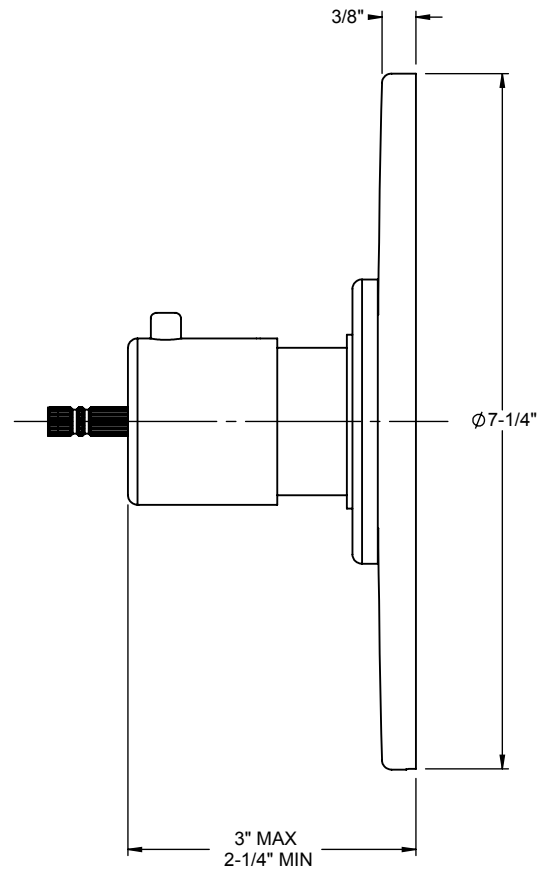

ALL DIMENSIONS SHOWN TO NEAREST 1/16"