

HBW

PRESSURE BALANCING INTEGRAL DIVERTER VALVE

-384-XXX (LESS DIVERTER)

-385-XXX (WITH DIVERTER)

-386-XXX (WITH SHOWERHEAD, LESS DIVERTER)

-387-XXX (WITH SHOWERHEAD, TUB SPOUT, AND DIVERTER)

Standard Installation

Same as pressure balance valve less diverter

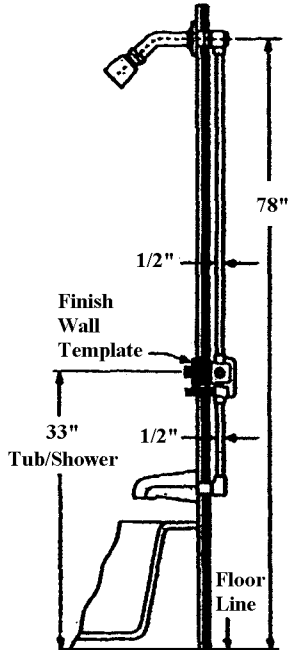

Back-to-back Installation

Cartridge must be rotated 180°

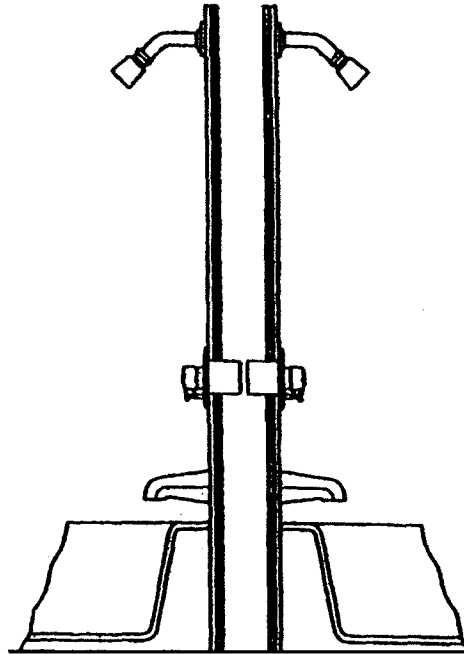

Specifications and Dimensions

Min. operating pressure: 20 PSI (140KPA)

Max. operating pressure: 125 PSI (1000KPA)

Burst pressure: 500 PSI (3450KPA)

Hot & cold inlets: 1/2" IPS or CXC

Shower outlet: 1/2" IPS or CXC

Tub outlet: 1/2" IPS or CXC

Flow capacity, shower: 7 GPM @ 45 PSIG

Flow capacity, tub: 6.8 GPM @ 45 PSIG

Finished wall adjustment: 3/4"

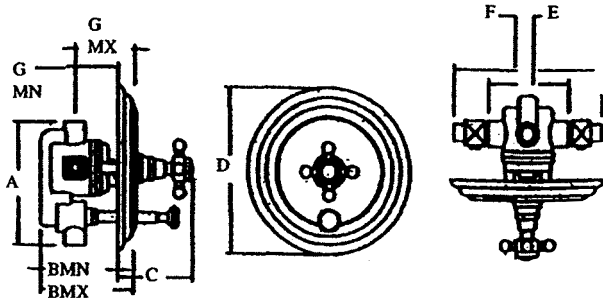

	A	Min B	Max B	C	D	E	F	Min G	Max G
Ins	6-1/2	3-3/4	4-1/2	3-1/2	7-3/8	3-13/16	6-3/4	2-1/2	2-13/16

062-N-25300T (With diverter)
 062-N-2445N (Less diverter)

- | | | |
|-----|---|--|
| 1. | 80-385L-XXX
80-384L-XXX | Large plate w/diverter
Large plate less diverter |
| 2. | 062-N-0792 | Nylon split washer |
| 3. | 062-N-252900
062-N-2529L
062-N-2529XL | Screw kit (1-3/8")
Screw kit (1-1/2")
Screw kit (1-3/4") |
| 4. | 062-N-IPS-XXX | Index plate screw |
| 5. | 062-N-0764-XXX | Diverter knob |
| 6. | 062-N-0785 | Intermediate stem |
| 7. | 80-385INDEX-XXX
80-384INDEX-XXX | Index plate w/diverter
Index plate less diverter |
| 8. | 062-N-RING-XXX | Ring |
| 9. | _80-384B-XXX | Bell for pres. balance |
| 10. | _80-012-XXX | Handle |

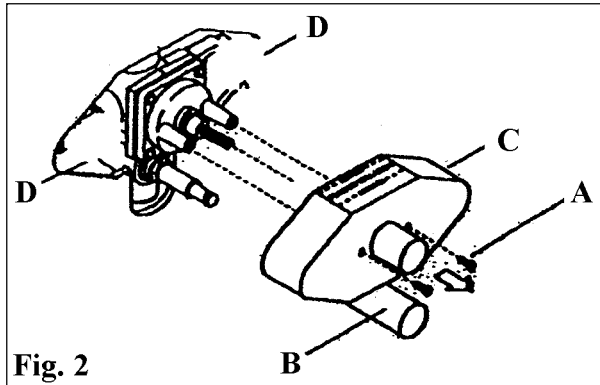
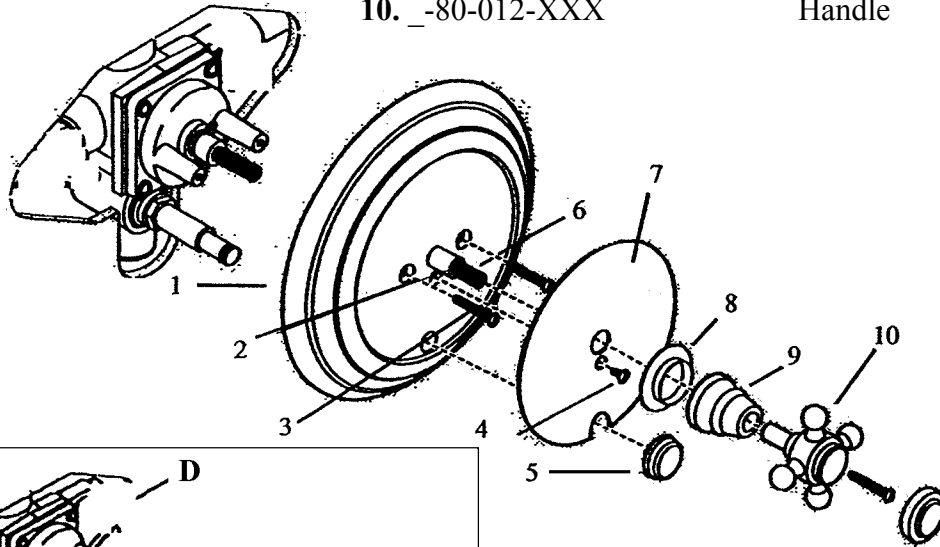

Fig. 2

Installation

- Remove the two screws (A) from the finished wall template, then remove the template (C).
- Remove the diverter protective sleeve (B).
- Make sure the hot & cold water supply is fully open.

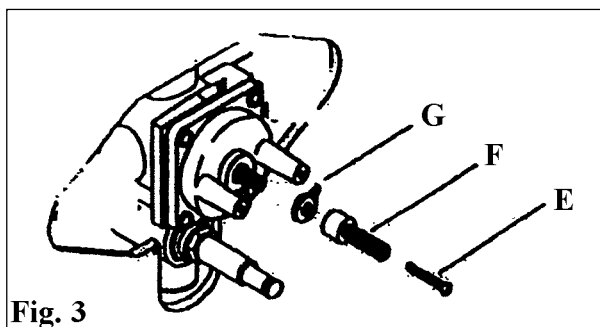

Fig. 3

Setting the hot limit stop

- Remove the screw (E) & the brass driver (F).
- Remove the hot limit stop (G).

- | | |
|---|------------|
| E | 062-N-1398 |
| F | 062-N-0793 |
| G | 062-N-0706 |

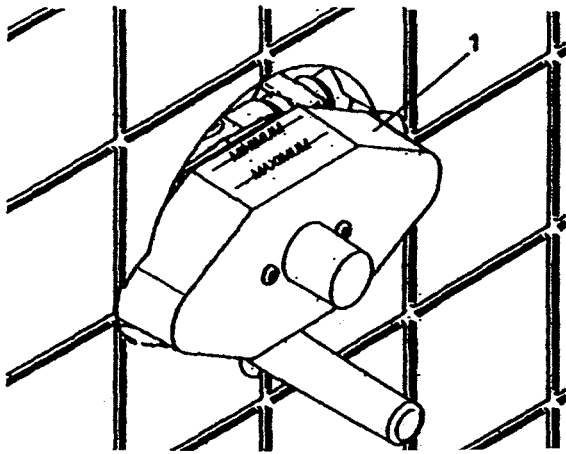

Fig. 4

Rough in

Position valve with 1/2" shower outlet marked "S" up and the 1/2" tub outlet marked "T" down. Finished wall must be within dimensions shown on finished wall template (1) (see Fig. 4 & 5).

Finished wall template (1) must remain intact for finished wall surface measurements and as a template for plastering and/or tilling (see Fig.4).

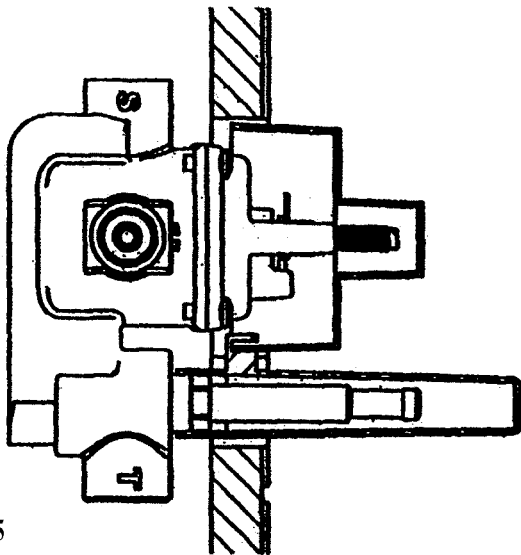

Fig. 5

IMPORTANT: it is not necessary to remove the pressure-balancing cartridge from the valve during normal soldering of connections using propane-butane gas. **Do not use OXYGEN-ACETYLENE when soldering CxC connections, do not use excessive heat!**

To test the pipe joints, pressurize both hot and cold inlets.

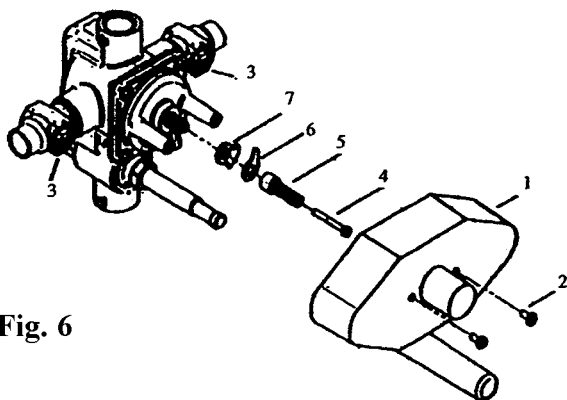

Fig. 6

Back to Back Installation

- Remove the two screws (2) to remove the finished wall template (1).
- If the valve body is equipped with service stop valves (3), close the hot and cold water supplies. Otherwise, shut down the supply at the nearest source.
- Remove the screw (4) to remove the brass valve stem driver (5).
- Pay close attention to the setting of the hot limit stop and mechanical stop (See Fig. 7).
- Remove the hot limit stop and the mechanical stop.

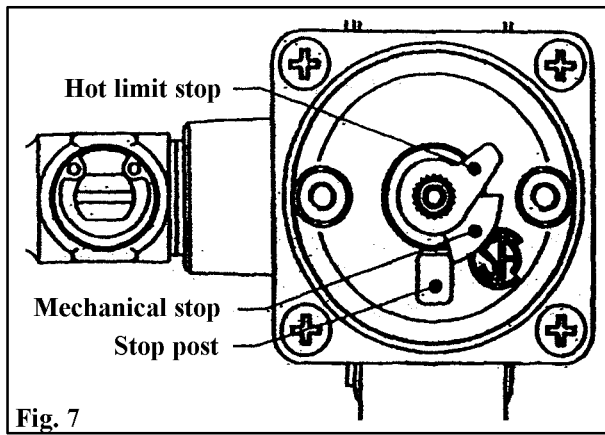

Fig. 7

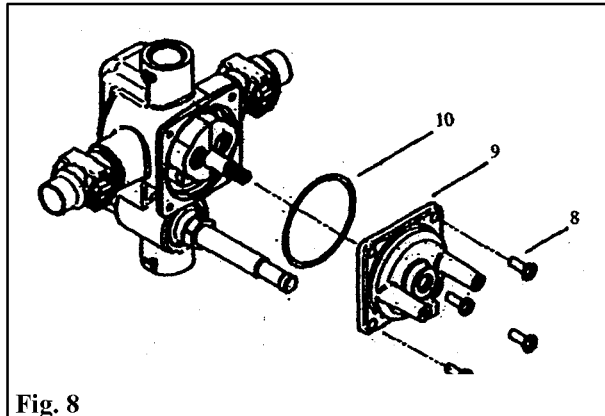

Fig. 8

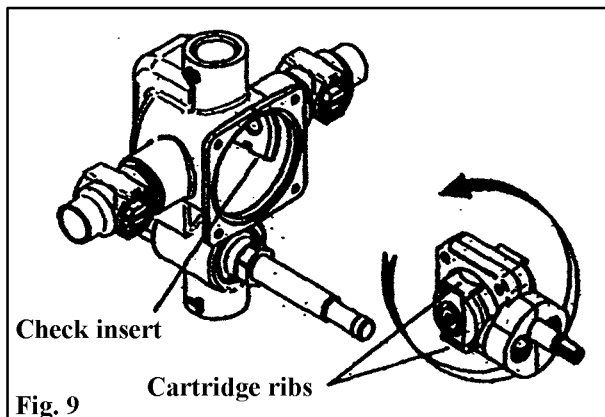

Fig. 9

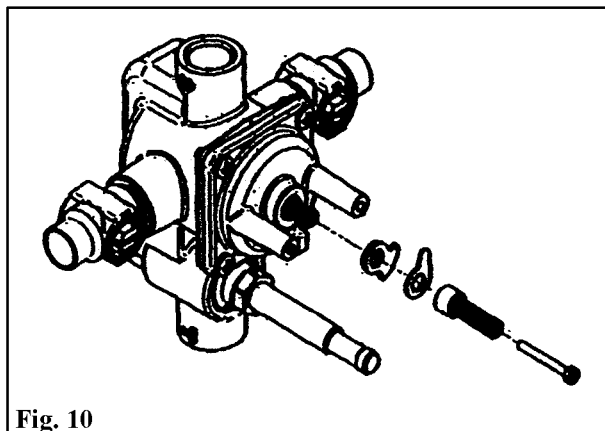
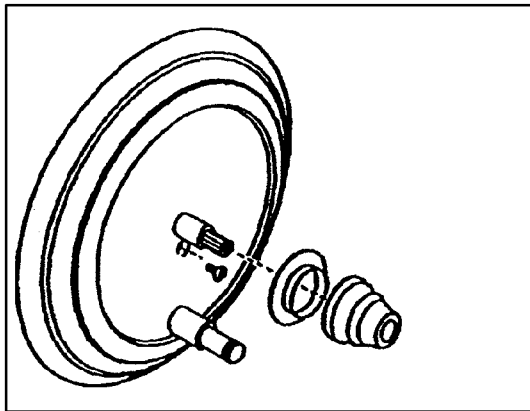
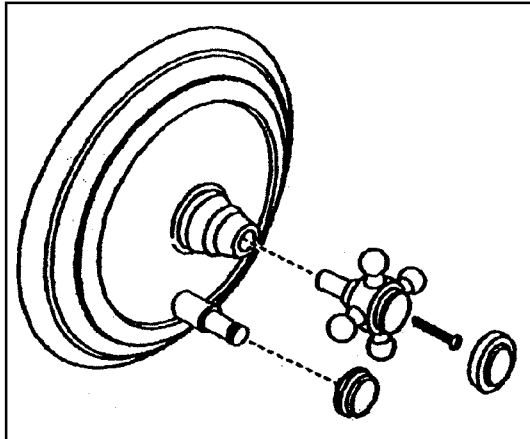

Fig. 10

- Loosen the four corner screws (7) and remove the valve cover (9) with the O-ring (10). The cartridge assembly is now exposed
- Pull the cartridge straight out of the valve body. Rotate the cartridge 180°. Place it into the valve body. Note position of hot ("H") and cold ("C") markings on the cartridge: "H" hot will now be on the right and "C" cold on the left. Make sure when sliding the cartridge into the body that check insert fits between two alignment ribs located on cartridge sides (Fig. 8). When correctly engaged the cartridge will not rotate. Take care not to damage cartridge inlet O-rings.
- Put the O-ring on the valve cover. Make sure the surface of the valve cover, on which the O-ring will sit, and the O-ring are both dean.
- Position the valve cover with stop post facing down. Seat the cover to the body. Do not pinch the O-ring. The assembly should fit together with a minimum of pressing force.
- Tighten the cover screws lightly in a diagonal pattern, then firmly close the valve by turning the cartridge stem clockwise. The stem driver can be used to turn the stem. Fit and position the hot limit stop and mechanical stop as shown in (Fig. 7) over the cartridge stem and push it into place.
- Install brass stem driver and secure with screw.
- Open stop valves.



- Position the index plate on the escutcheon and secure with the index plate screws.
- Place the index ring on the index plate and screw the bell to the escutcheon.



- Install the handle on the intermediate stem and secure it with the handle screw.
- Screw the handle cap onto the handle.
- Screw the diverter knob onto the diverter stem.

Trouble Shooting

Malfunction	Cause	Remedy
Hot & cold reversed	Hot and cold water supplies have been connected in reverse.	Rotate cartridge as described in "Pressure Balancing Integral Diverter Valve Installation Instructions"
Tub filler or shower head drips after shutting off the valve.	Water remains in the piping column to the shower head. (This is normal.) Incorrect setting of the mechanical stop against the stop post causing a partially open cartridge. Cartridge inlet O-rings or the check insert O-rings faulty.	Allow approximately 3-5 minutes to drain column. Reset the mechanical stop as described in "Pressure Balancing Integral Diverter Valve Installation Instructions". Check O-rings on the cartridge inlets and check inserts for cuts or damage; replace if necessary.
Shower insufficiently hot.	Hot limit stop position set incorrectly.	Refer to instructions on setting the hot limit stop in "Trim Set for Concealed Integral Diverter Valves Installation Instructions". Check hot water source.
No flow of hot or cold water.	Either the hot or cold supplies or not fully pressurized. Debris in checks.	Be sure service stops are both wide open and system is fully pressurized. Remove the cartridge, check inserts and checks. Remove any debris lodged in checks.

Note: At no time try to stop dripping by applying extreme force when closing the valve!

Spare Parts

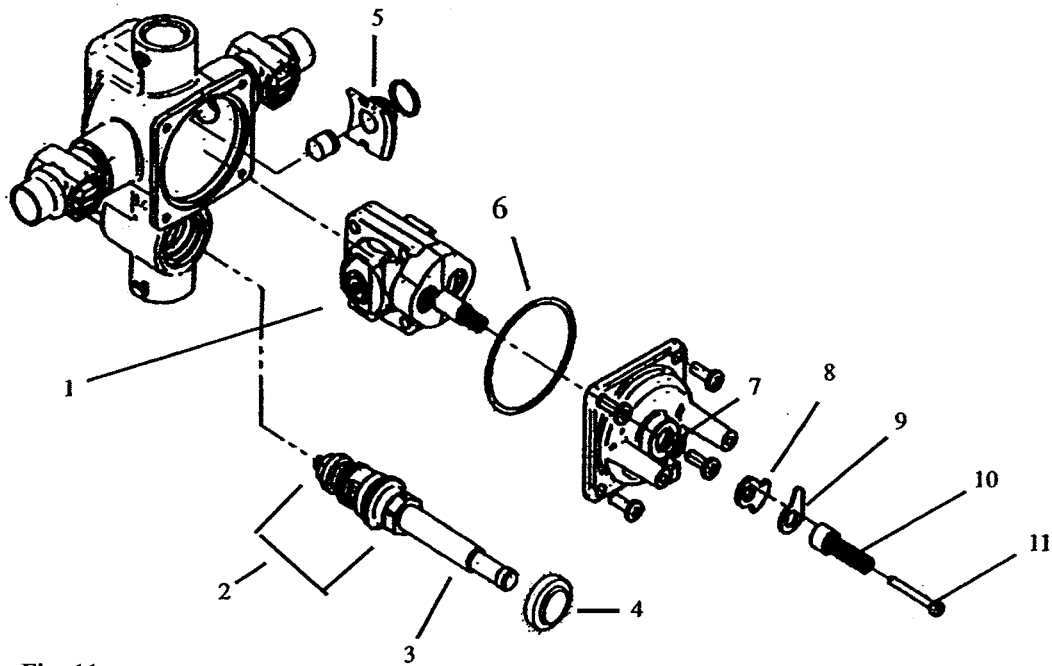

Fig. 11

- | | | |
|-----|----------------|-----------------------------------|
| 1. | 062-N-128500 | Cartridge (old style) |
| | 062-N-128500T | Cartridge (new style) |
| 2. | 062-N-26500 | Diverter cartridge |
| 3. | 062-N-2586-XXX | Diverter trim kit (knob included) |
| 4. | 062-N-0764-XXX | Diverter knob |
| 5. | 062-N-1000 | Inserts w/ checks |
| 6. | 062-N-0378 | O-ring |
| 7. | 062-N-0317 | O-ring |
| 8. | 062-N-0696 | Limit stop |
| 9. | 062-N-0716 | Hot stop |
| 10. | 062-N-0793 | Driver |
| 11. | 062-N-1398 | Screw |

Maintenance

The cartridge is designed for the minimum of maintenance in normal domestic use. If a malfunction occurs, a complete cartridge replacement will probably be necessary. The cartridge contains no internally serviceable parts. Contact your installer or dealer.